

HARDWARE REQUIRED FOR STARTER & ADD-ON ASSEMBLY

QTY	PART #	DESCRIPTION
4	00060-1157	5/16-18 Hexnut
4	00060-1171	5/16 Capscrew
4	00060-1275	5/16 split lock washer

HARDWARE REQUIRED TO ATTACH ASSEMBLIES TO FIXTURE

QTY	PART #	DESCRIPTION
1 per connection point	08308-0297	5/16 U-nut
1 per connection point	00060-1171	5/16 Capscrew
1 per connection point	00060-1240	5/16 washer
Please see note below	08445-1720	Spacer plate

NOTE: Spacer plates are only required at the end of a gondola run under the bottom arms (with the exception of attaching two (2) starter assemblies as pictured in step 2).

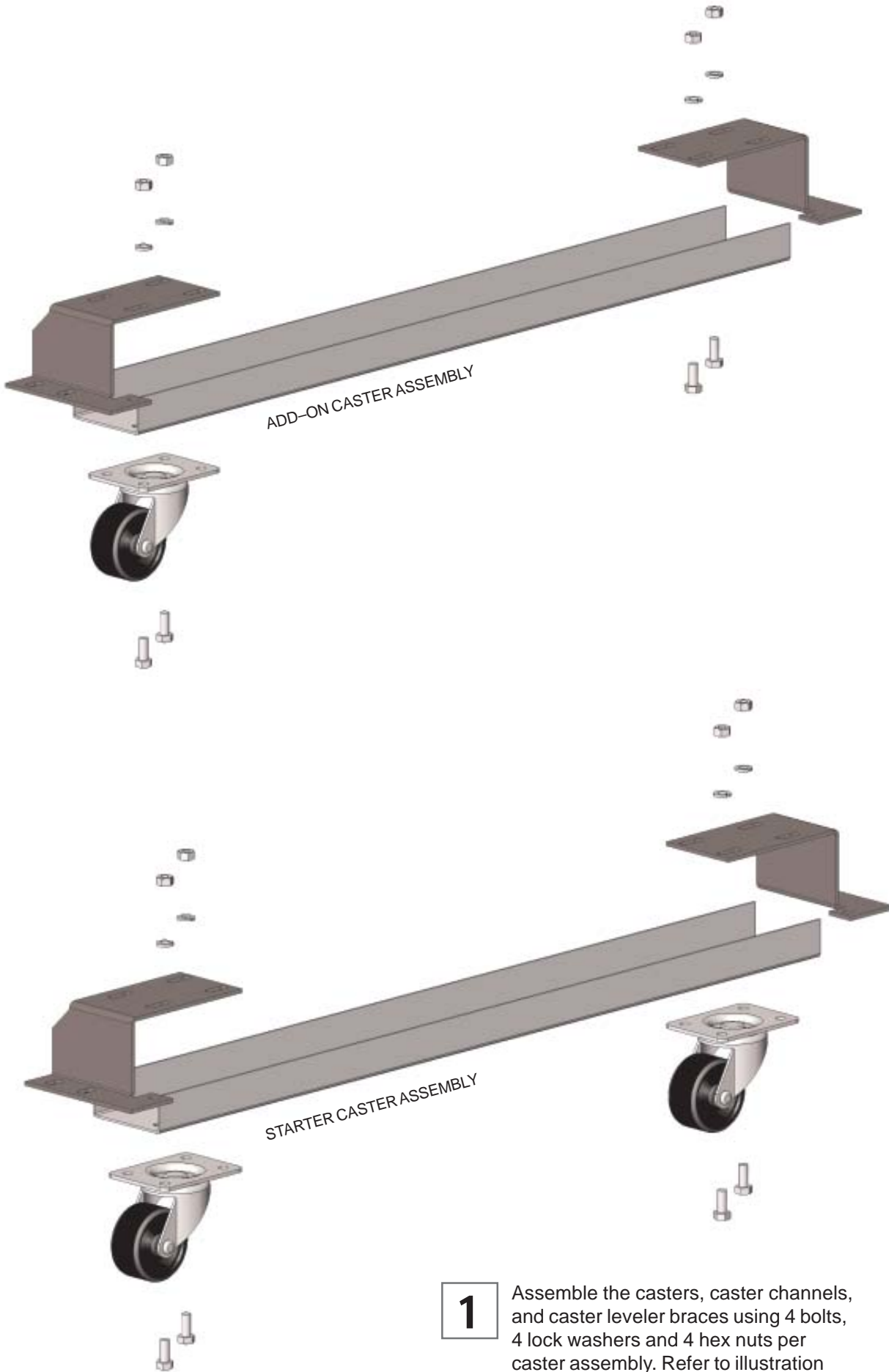

1

Assemble the casters, caster channels, and caster leveler braces using 4 bolts, 4 lock washers and 4 hex nuts per caster assembly. Refer to illustration above.

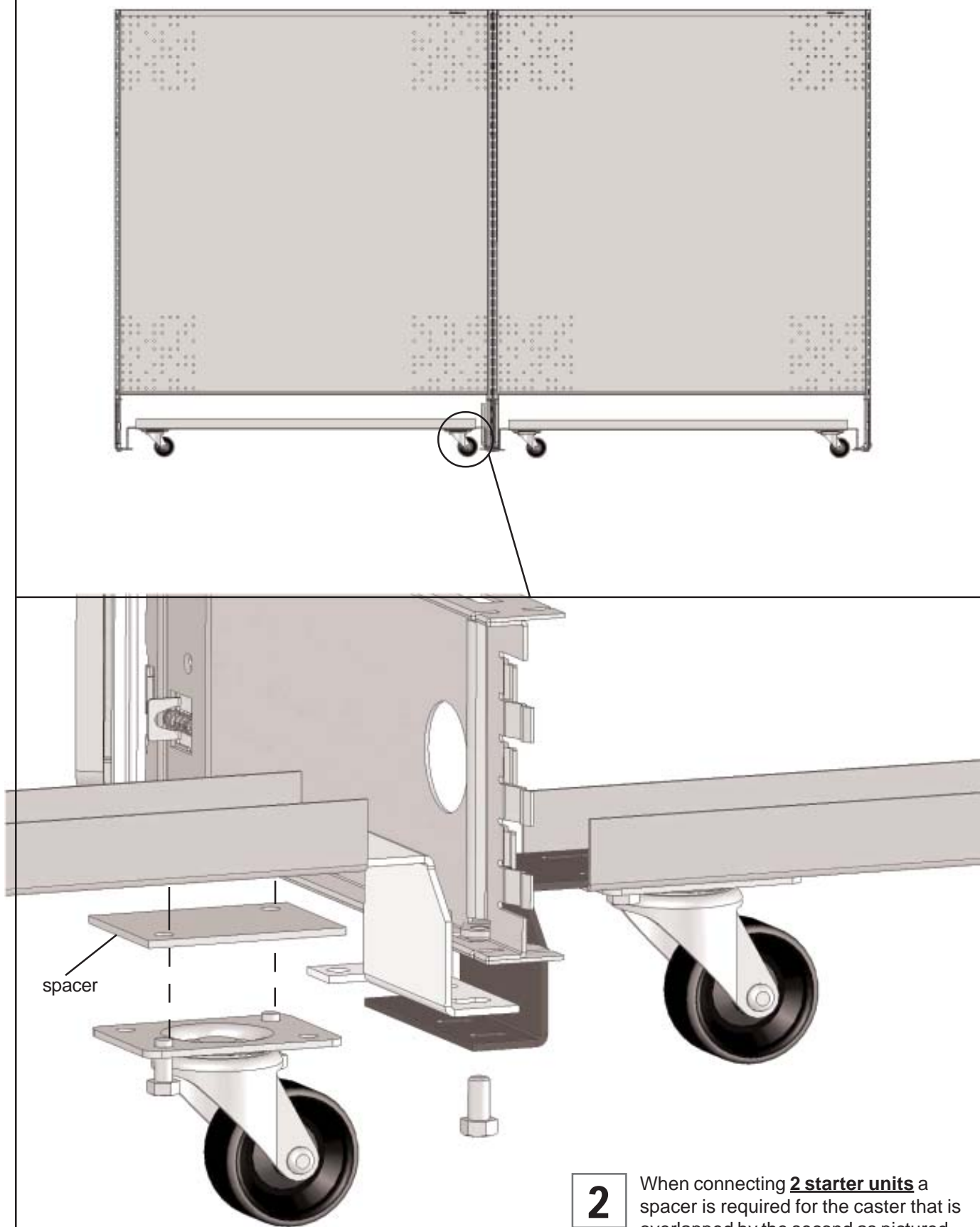
**2**

When connecting **2 starter units** a spacer is required for the caster that is overlapped by the second as pictured above. With the spacer installed slide the casters one above another as pictured above and bolt together.

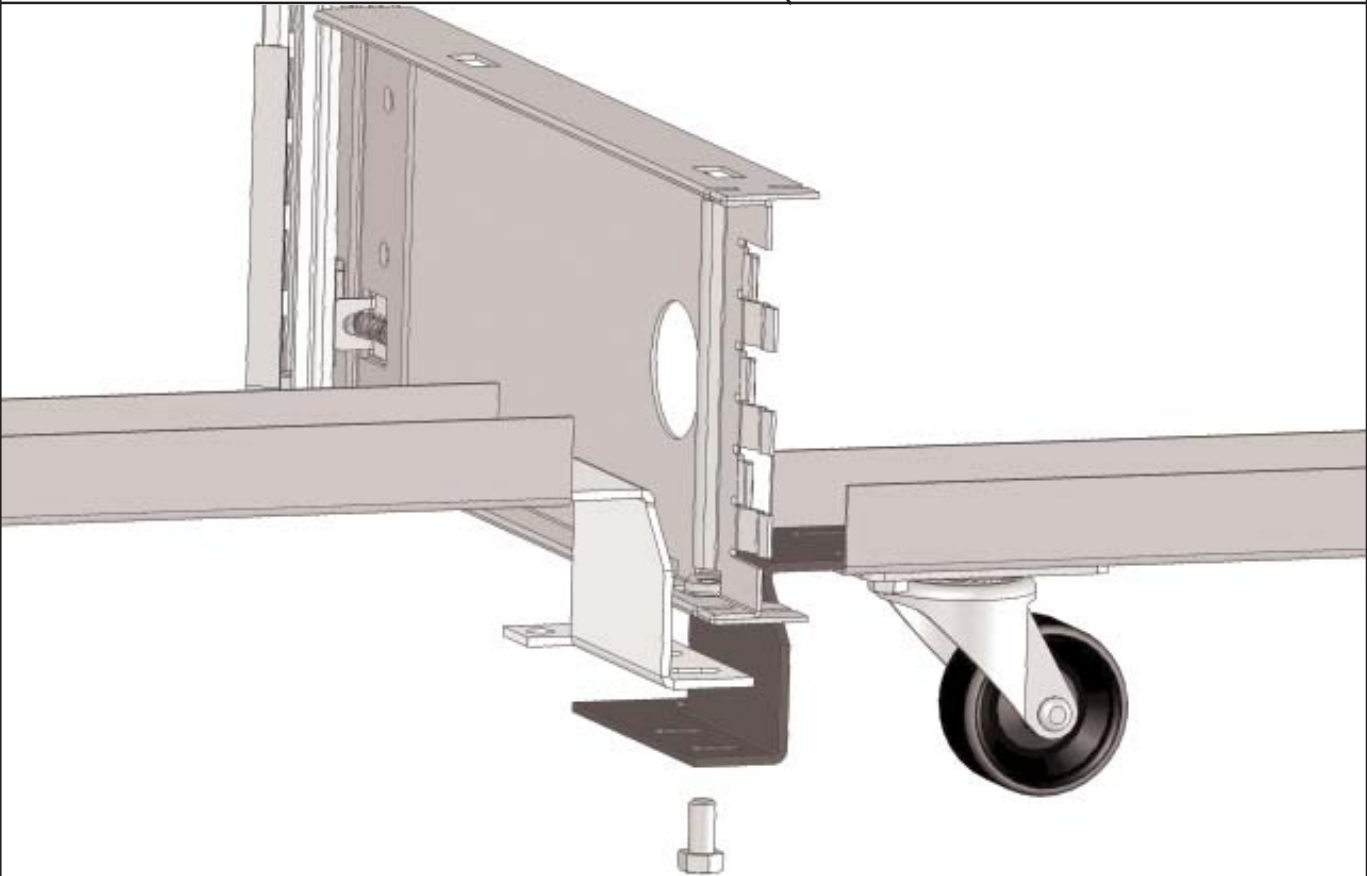
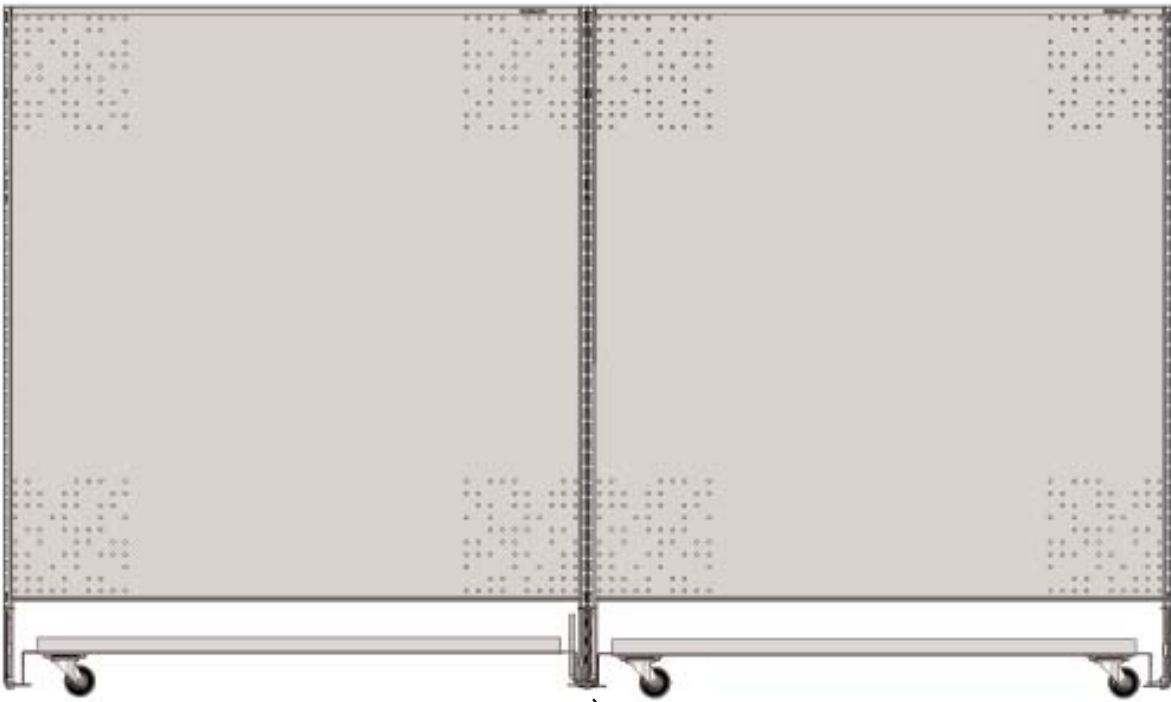

3 When connecting a **starter to an add-on unit** no spacer is required. Just slide the casters one above another as pictured above and bolt together.

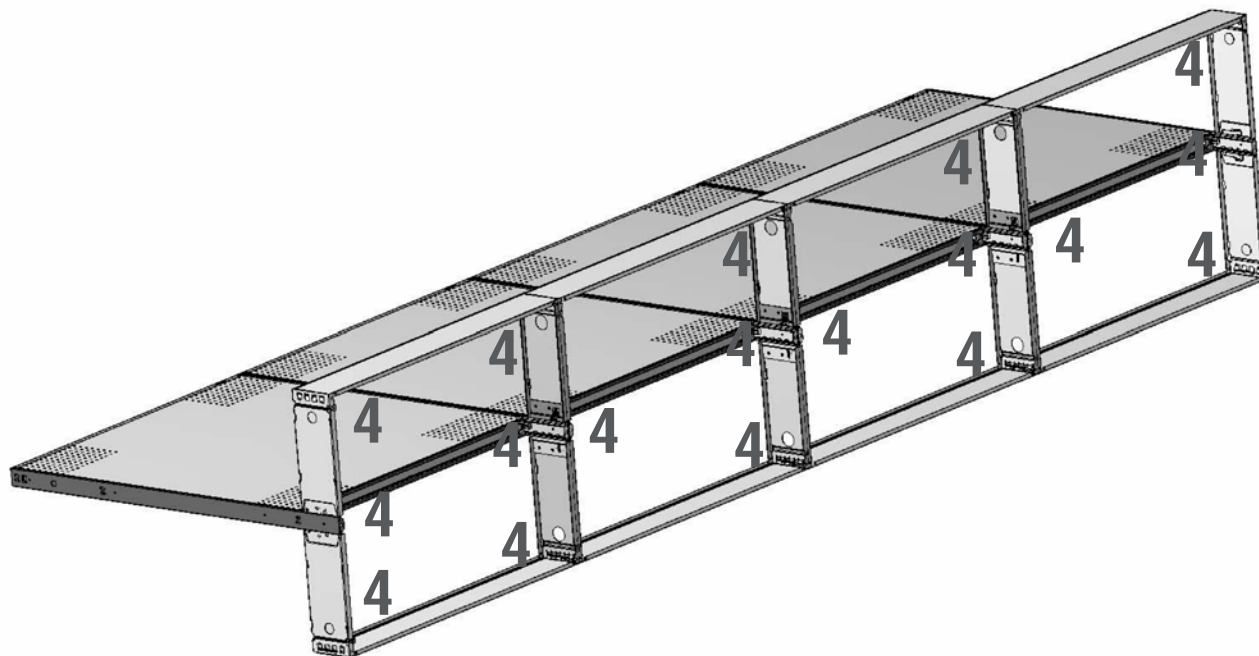

End standards get one (1) clip and center standards get two (2) clips

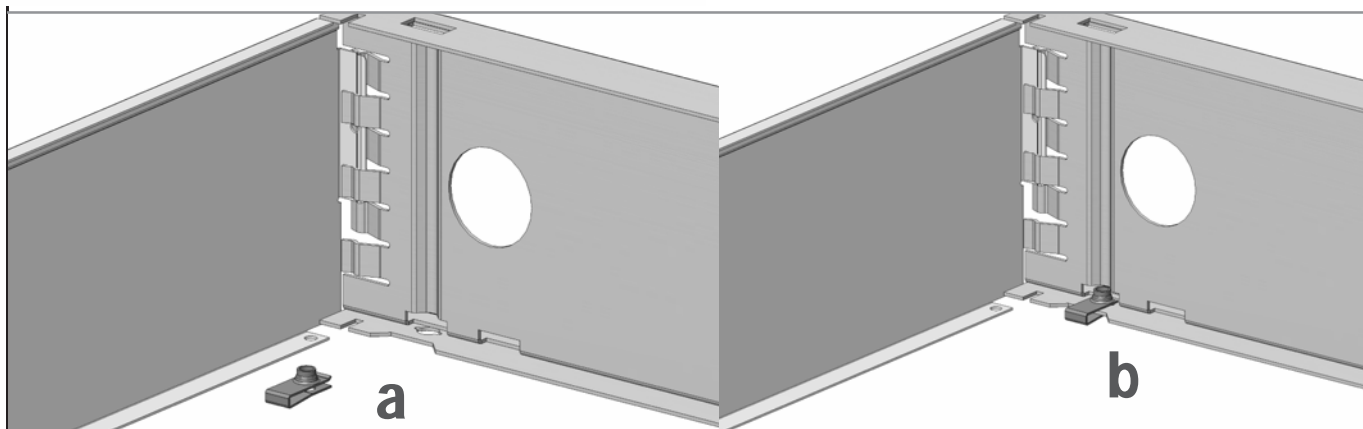

End and center bottom arms get one (1) clip

4

Slip the tinnerman clip over the end standard, center standard, end bottom arm, and center bottom arm as pictured above. The flat side of the tinnerman nut should be on the bottom of the module.

5

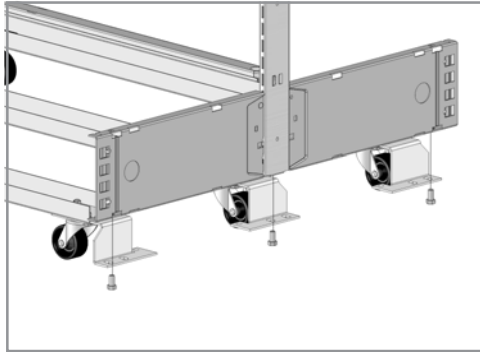
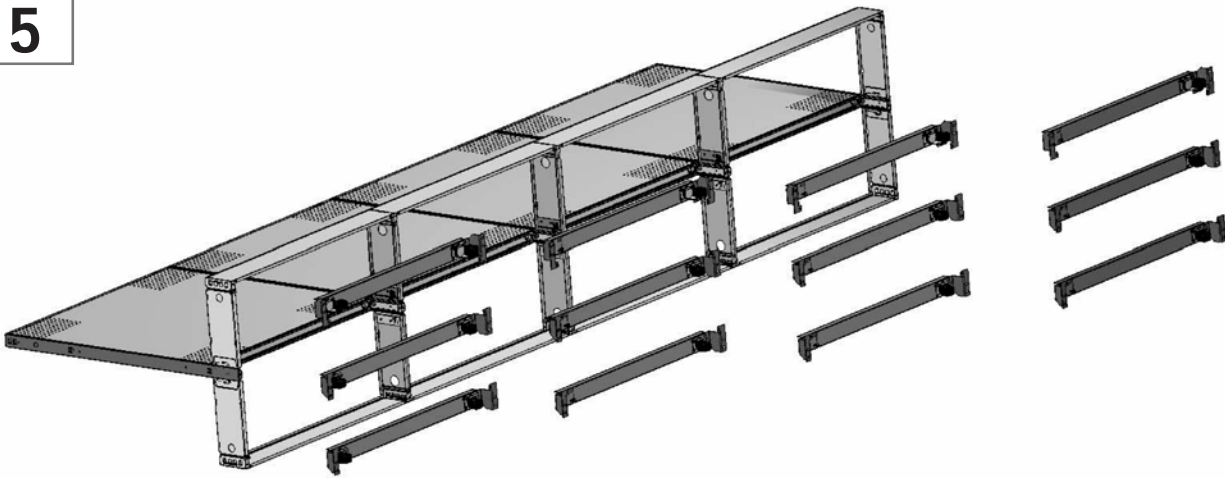

a

Attach caster assemblies to the end bottom arms by aligning the outside hole on the caster assembly with the hole in the bottom arm and secure with 1 5/16 X 3/4 bolt per bottom arm.

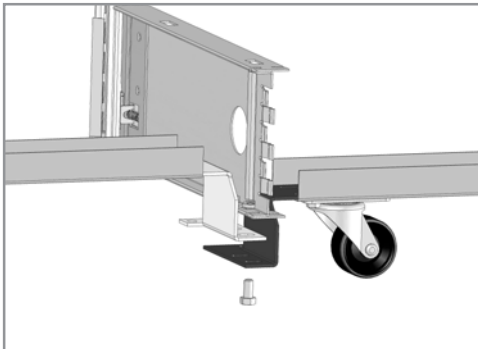

b

Attach the starter caster assembly and the add on caster assembly by overlapping them under the center bottom arm as pictured above and secure with 1 5/16 X 3/4 bolt per bottom arm.

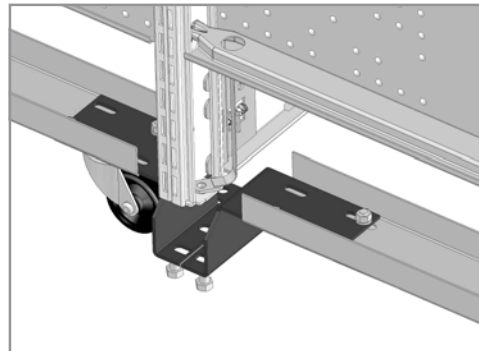

c

Attach caster assemblies to end and center standards by aligning the inner-most hole on the caster assembly with the hole in the bottom and the standards and secure it with 1 5/16 X 3/4 bolt per end of caster assembly.

Casters under the center standards should not overlap and should be secured independently.

STARTER TO ADD-ON GONDOLA RUN

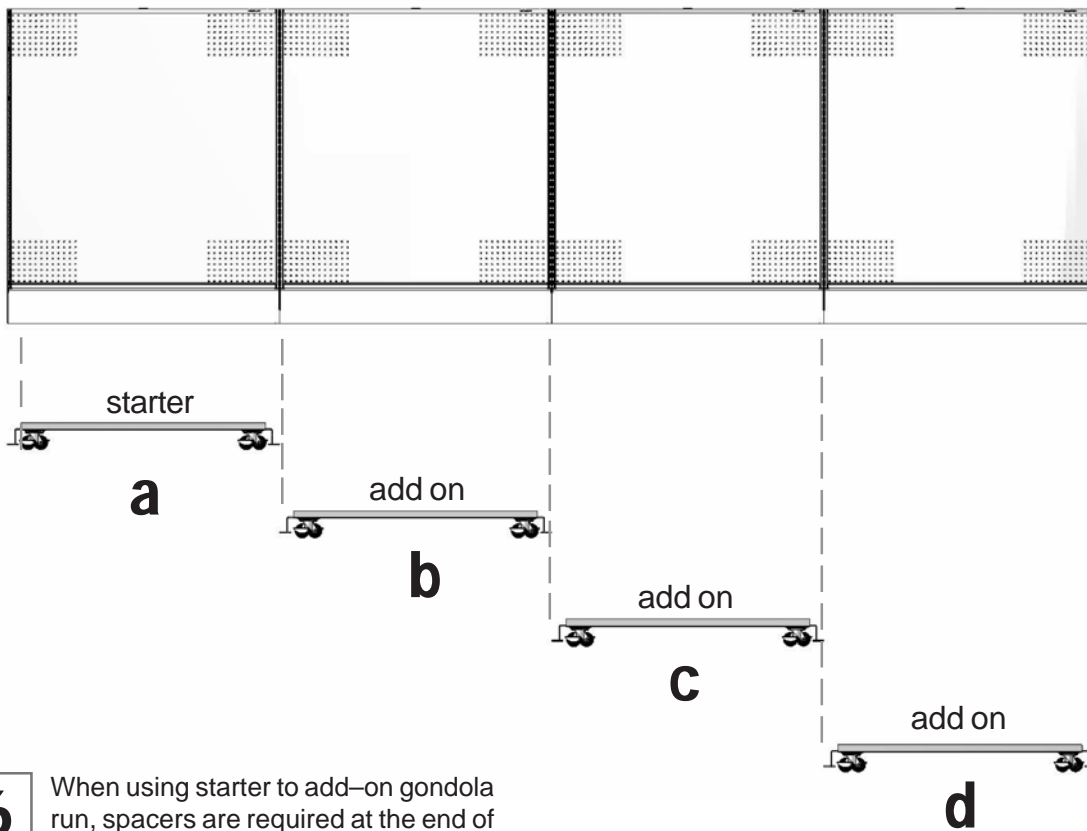
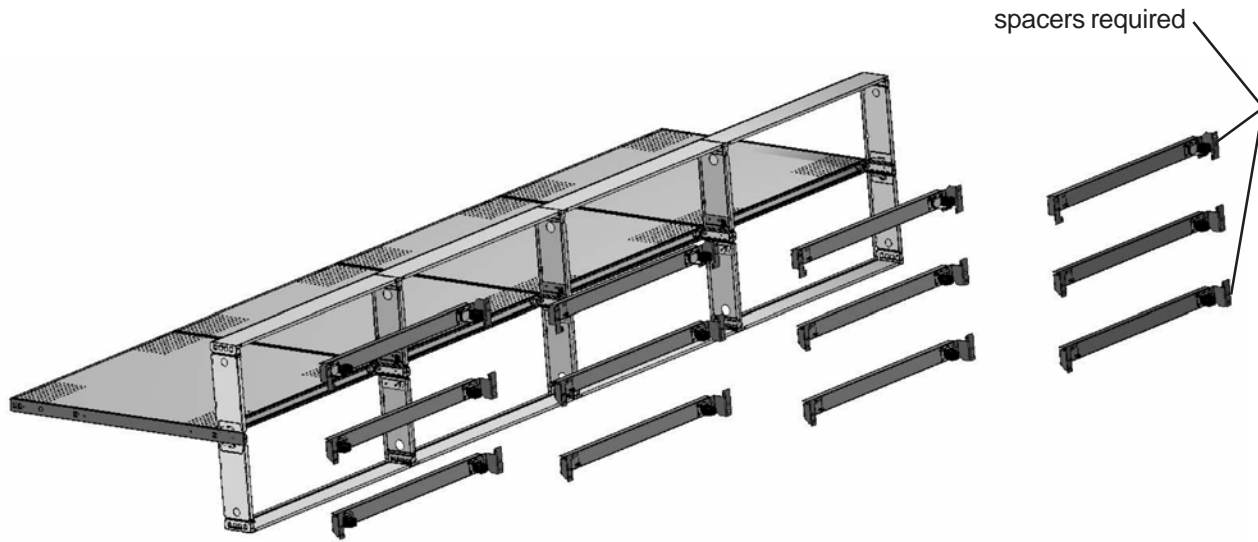

6 When using starter to add-on gondola run, spacers are required at the end of the run as pictured above. Refer to step 2 for installation.